

FIELD

REMOTE I/O

MCC BUCKET

PANEL

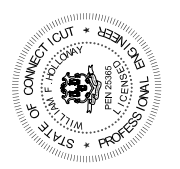
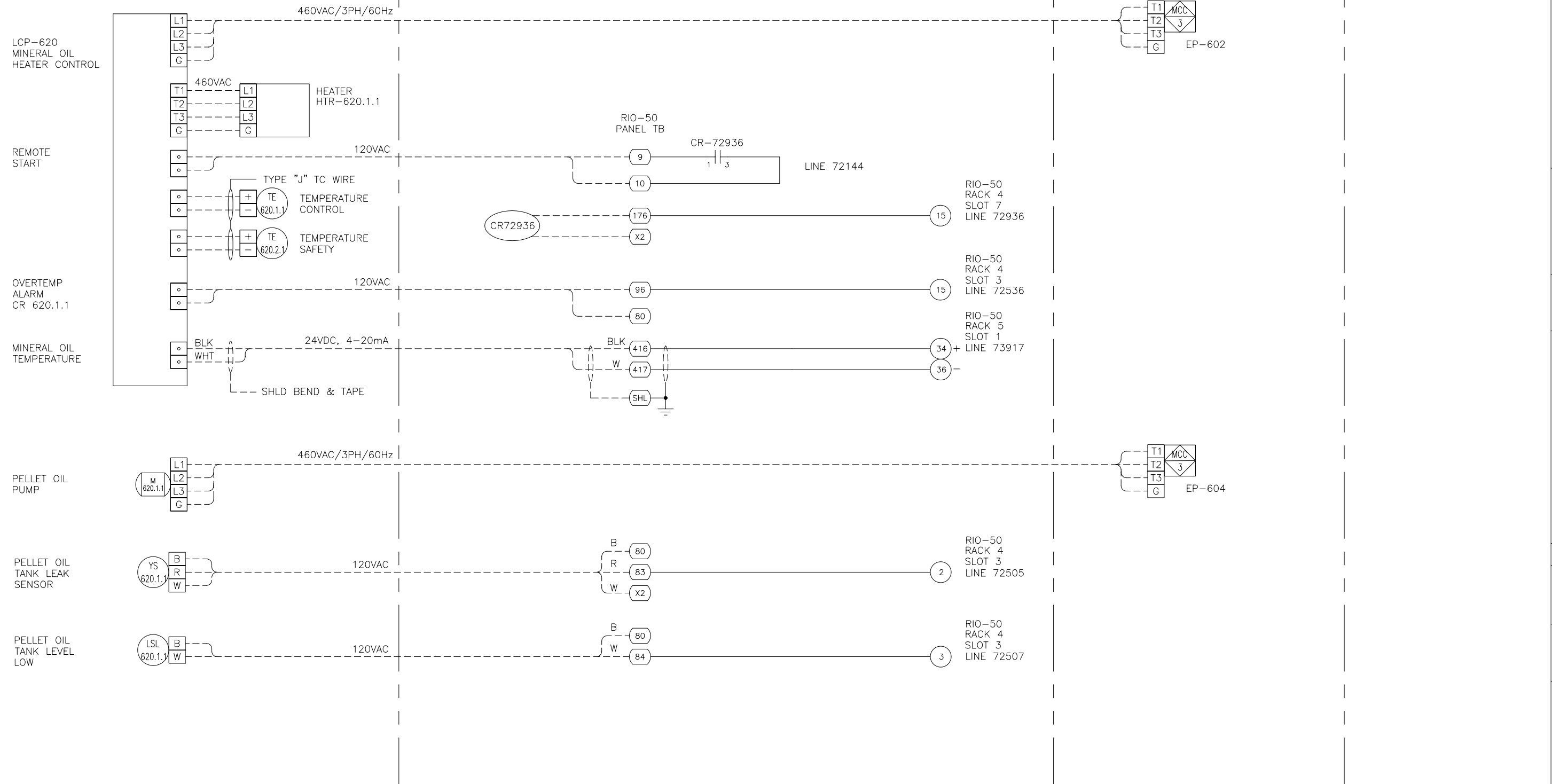

DATE	REV	DESCRIPTION
12/08/06	0	FOR FINAL REVIEW/BUILDING PERMIT

DATE: 3/21/06	FILE: 1524E1856
CHECKED BY:	SIZE:
APPROVED BY:	SCALE: NONE
DDS40	

JOB NAME: CITY OF STAMFORD CONNECTICUT SOLIDS DRYING PROJECT	TITLE: PELLETIZING TRAIN GROUP 620 LOOP DIAGRAM
PROJECT NUMBER: 1524	DRAWING NUMBER: EI-856
SHEET: 1 OF 1	REV: 0

TAG	DESCRIPTION	MANUFACTURER	MODEL NO.	CALIBRATION
LCP 620	LOCAL CONTROL PANEL			X
TE 620.1.1	TEMP ELEMENT			X
TE 620.2.1	TEMP ELEMENT			X
M 620.1.1	MOTOR			X
YS 620.1.1	LEAK DETECTOR	GEMS	164222	X
LSL 620.1.1	LOW LEVEL SWITCH	GEMS	164870	X

THIS DRAWING IS COPY RIGHTED AND IS THE PROPERTY OF ANDRITZ-RUTHNER, INC. IT IS TO BE USED ONLY FOR THE PROJECT AND SITE SPECIFICALLY IDENTIFIED HEREIN. IT IS NOT TO BE REPRODUCED, COPIED, OR TRANSMITTED IN ANY FORM OR BY ANY MEANS, ELECTRONIC OR MECHANICAL, INCLUDING PHOTOCOPYING, RECORDING, OR BY ANY INFORMATION STORAGE AND RETRIEVAL SYSTEM, WITHOUT THE WRITTEN PERMISSION OF ANDRITZ-RUTHNER, INC.

RELEASED 12/08/06
REVISION - 0

